

Downflo® Oval Dust Collectors



Downflo® Oval

A Family Of Over-Achievers

The high performance Downflo® Oval (DFO) family of over-achieving dust collectors is the best value available. Providing up to 25 percent more filtration capacity than same-sized cartridge collectors, DFO adds up to long-term savings and better performance.

The DFO advantage is found in the collector's patented design and components. Proprietary, ultra efficient filter media and cleaning technology allow more airflow through the collector without increasing the size of the footprint or damaging the filters.

A smaller collector helps lower the initial purchase price, reduces filter replacement costs and opens up valuable manufacturing floor space.

25%
MORE
CAPACITY

DFO Offers:

- **Lower initial cost per cubic foot of air per minute (cfm)**
- **Long-term energy savings**
- **Fewer filter changeouts**
- **Reduced filter disposal cost**
- **Easy system set-up**
- **Less maintenance**
- **10-year warranty**



DFO 3-18

Downflo® Oval

Outperforms All Other Collectors

The full line of DFO collectors offer a variety of benefits that distinguish them from all other collectors available in the market today.

- **Easy to use** Quick-release handles provide easy cover removal and faster filter access.
- **Compact** Smaller footprints for applications that require maximum cleaning efficiency in even smaller spaces.
- **Powerful** DFO collectors provide 25 percent more capacity than same-sized dust collectors.
- **Cost effective** The patented ExtraLife™ Filter Cleaning System averages up to 30 percent increase in pulse cleaning energy for unmatched cleaning ability.
- **Innovative** Unique oval-shaped Ultra-Web® cartridge filters provide the longest filter life and highest filtration efficiency – which lowers cost.



DFO 2-4



DFO 3-3

Downflo® Oval

Sizes & Operations

Normal Operations For Models 1-1, 2-2 and 3-3

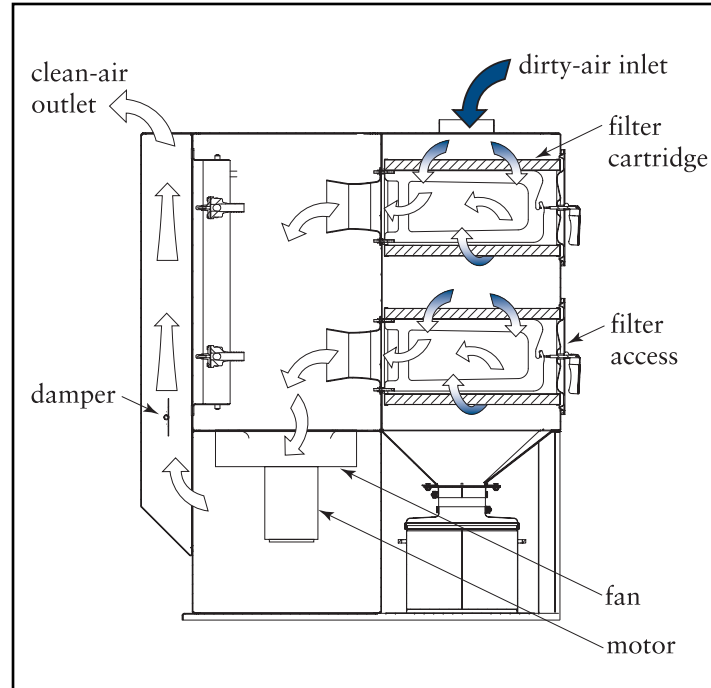

DFO 1-1

DFO Models 1-1, 2-2 and 3-3

- Incorporates several exclusive and unique features
- Completely self-contained, "plug-and-play" type units
- Packaged with power pack, controls, silencer, damper, dust container and more
- Remarkably quiet operation
- Exceptionally compact design
- Easily movable through standard aisles and doorways

Sizes & Operations

Normal Operations For Models 2-4 Through 4-128

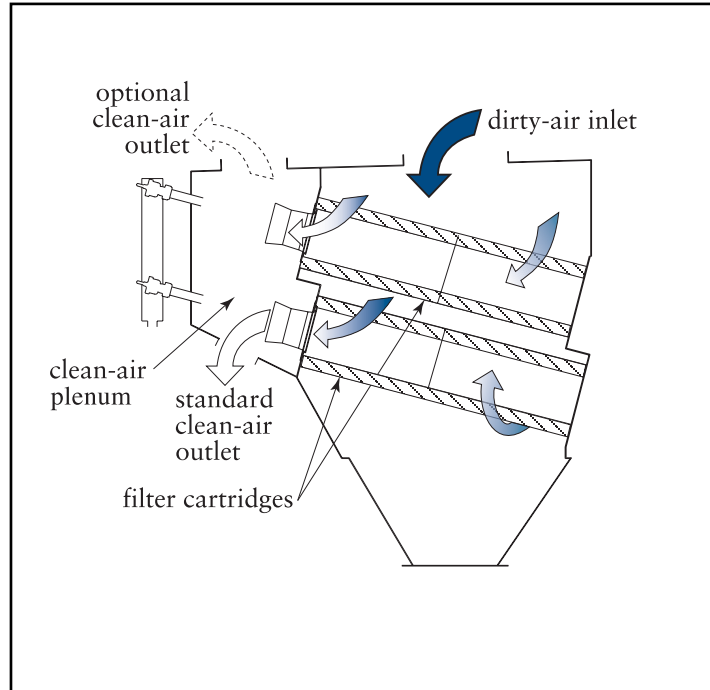

DFO Models 2-4 to 4-128

- 23 standard model sizes
- Customized sizes available
- Many options and accessories
- Exceptionally compact design
- Highest energy savings

*Simply
the Best
Dust Collectors
Available*



Downflo[®] Oval

DFO Technology Unfolds

*The Remarkable Story of DFO
Begins with the Oval Cartridge Filter Itself*

Ultra-Web Nanofiber Media A dramatic departure from traditional circular-shaped cartridge filters, DFO's oval-shaped filters, in conjunction with our patented nanofiber filter media, trap more dust on the surface of the filter than conventional commodity types of filter media such as depth-loading cellulose, polyester or cellulose/polyester blend.

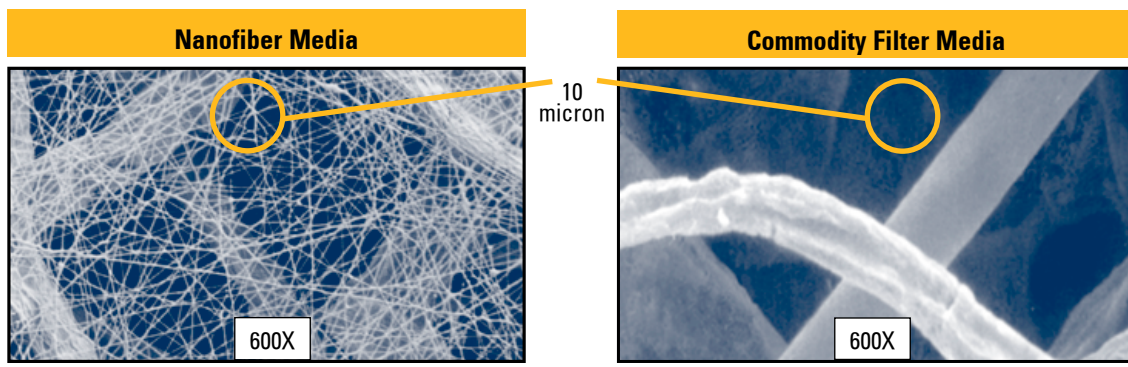

Nanofiber technology is available in all Ultra-Web and Fibra-Web filter cartridges.

Conventional media has spaces of up to 60 microns between fibers, allowing dust to become deeply embedded.

*The Innovation Continues with
DFO's Shorter, Stiffer Filter Pleats*

DFO Filter Media Pleats Shorter and stiffer filter pleats help minimize dust entrapment and simplify filter cleaning. By reducing the height of the filter pleats from the standard 2 inches to 1.5 inches, the pleat wall is less likely to collapse or bend, which can encapsulate dust and prevent its expulsion.

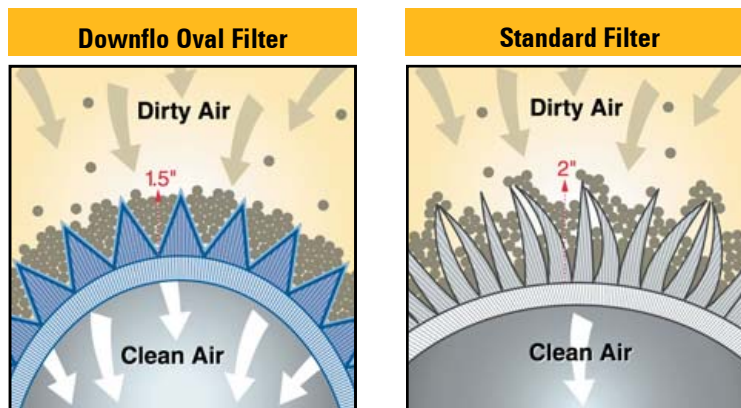

Downflo[®] Oval

More Airflow, Less Filter Media

*New Oval Shape
Contributes to Higher Airflow Capacity*

High Performance Filters The Downflo Oval filter design is a reflection of Donaldson Torit's commitment to technical research and development. Oval-shaped filters handle up to 25 percent more airflow without increasing velocities, which can cause filter abrasion. Sophisticated FLUENT[®]* Airflow Modeling Software revealed that oval-shaped cartridge filters have fewer areas of high velocity, resulting in a lower potential for media abrasion and increased filter life.

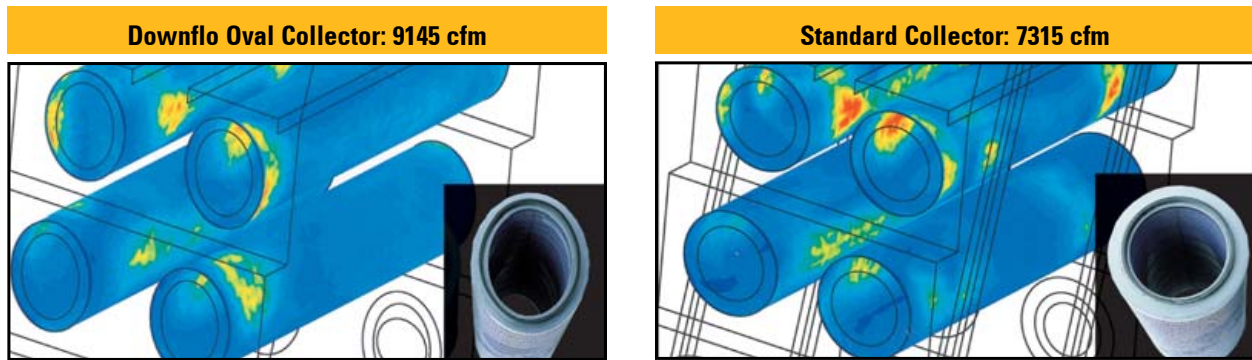

*Airflow Breakthroughs Lead To
A New Chapter In Filtration Performance*

Sophisticated Modeling Computer modeling for fluid dynamics, structural mechanics and acoustics puts DFO models 1-1, 2-2, and 3-3 in a technical class all their own. The illustration below (left) shows how FLUENT Flow Modeling Software enhanced the uniform air velocity distribution through model DFO 3-3. ANSYS[®]* Structure Analysis Software shown below (right) demonstrates lowest stress levels and deflections for model DFO 3-3 under typical operating pressures.

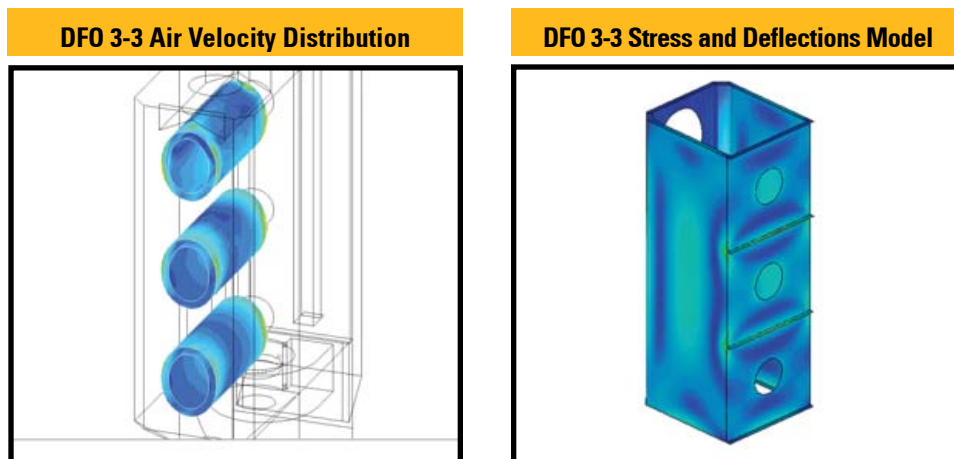

* FLUENT is a registered trademark of Fluent, Inc.; ANSYS is a registered trademark of ANSYS, Inc.

Downflo[®] Oval

Better Filtration, Prolonged Filter Life

*Technical Discoveries Improve Filtration Performance
And Prolonged Filter Life*

Convex Side Walls A new cabinet design with convex side walls streamlines the airflow path and increases the cabinet's cross-sectional area. The convex side walls provide more space between filters, lower cabinet velocities and reduce the potential for media abrasion.

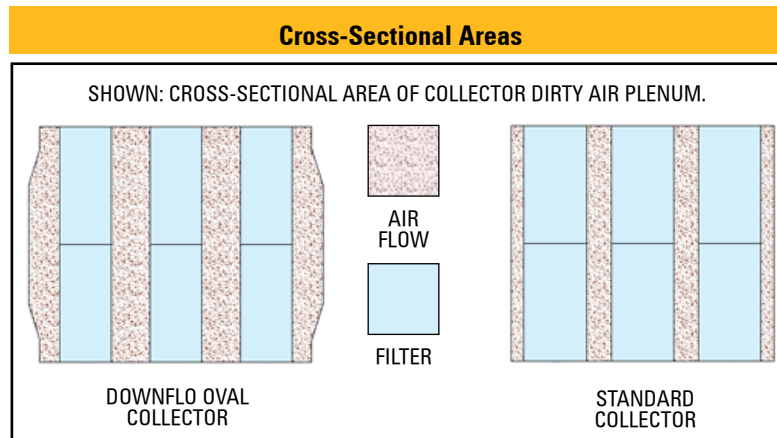

Pulse Cleaning Technology ExtraLife Filter Cleaning System uses proprietary, computer-modeled pulse cleaning technology to easily “pulse off” dust from the surface of the filter, improving filtration efficiency and prolonging filter life. The red lines in the illustration show the increased pressure at the front of the Downflo filter generated by the ExtraLife system. The blue line shows the pulse signature of a standard cartridge collector.

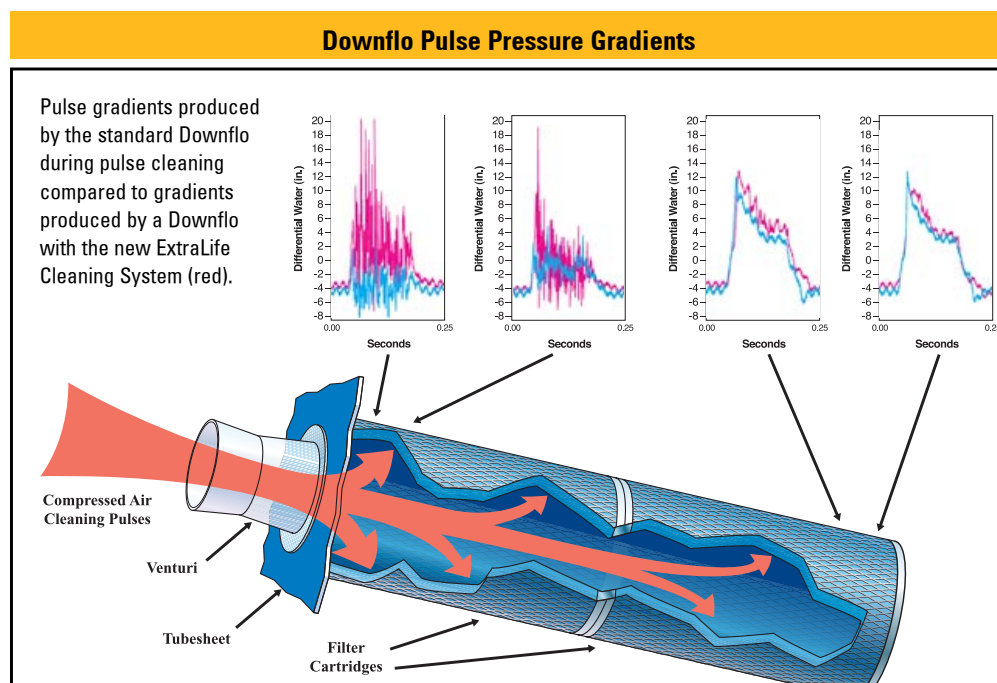

DFO Cartridge Filters For Many Applications

The DFO patented airflow design, its patented ExtraLife Cleaning System, and Donaldson Torit's unique oval-shaped filter cartridges are an unbeatable system. Choose from our superior line of filters to complete the most powerful filtration solution available for your application.

Ultra-Web® advanced nanofiber surface filtration technology ensures unequaled efficiency of 99.999% @ 0.5 micron dust particles, longest filter life, and greatest energy savings for most applications.

- Ultra-Web
- Ultra-Web FR (flame retardant)
- Ultra-Web NL (a "no-liner," banded construction for enhanced dust release on statically charged dust)



Fibra-Web® offers filtration solutions for fibrous, non-fibrous and agglomerative applications. A proprietary media featuring nanofiber technology and wider pleat spacing provides long filter life and efficiency of 99.999% on 0.5 micron dust particles.

- Fibra-Web
- Fibra-Web FR (flame retardant)

Thermo-Tek® proprietary synthetic media blend, a special heat-resistant construction and gaskets maintain seal strength and integrity at temperatures up to 275°F (135°C).



Ultra-Tek® media is ideal when collecting coarser, fibrous dust. Proprietary synthetic media blend results in longer filter life, high efficiency and easier dust release during pulse cleaning.

Torit-Tex™ filters provide exceptional filtration efficiency of 99.999% on 0.5 micron dust particles in moist, hygroscopic and agglomerative applications. Quick-release Tetratex® PTFE membrane technology supplies superior strength and maximum release capabilities in difficult applications.

* Tetratex is a registered trademark of Tetratex Corporation, a Donaldson Company.

Downflo[®] Oval

Filter Changes and Discharge Maintenance

Easy Maintenance With the new design of the DFO's quick-release access handles, filter removal and maintenance is extremely fast with one simple movement of the clamp.



Bag-In/Bag-Out Arrangements Improve filter changeouts and hopper discharge maintenance, help minimize worker exposure to potentially harmful dusts, and reduce exposure of contaminants to the atmosphere.



- Porthole covers protect changeout bags and provide a clean appearance.
- Heavy-duty plastic bags hold filters and function as gloves during the changeout procedure.
- Filters are disposed of in a sealed bag.
- Bag-in/Bag-Out drum arrangement is safely held in place through drum latches and hose clamps.

Operating Advantages & Conditions

DFO Models	1-1	2-2	3-3	2-4 through 4-128
Horse Power	1.5	3	5	**
Sound Level dB(A)*	68	68	70	**
External Static Pressure ("wg)	***	***	***	**
Housing Construction (gauge)	12	12	12	10 (collector) 7 (tubesheet)
Housing Rating (inches H ₂ O)	-20	-20	-20	-20
Wind Load Rating (mph)	–	–	–	100
Seismic Rating (zone)	4	4	4	4
Compressed Air Required (psig)	60	60	60	2-4, 3-6: 60 2-8 and up: 90-100
Electrical Power	120 VAC,	120 VAC,	120 VAC,	120 VAC,
Valves/Controls	50/60 Hz	50/60 Hz	50/60 Hz	50/60 Hz

* Sound measurements were taken in a hemianechoic chamber and under free field conditions and do not reflect the influences of actual operating environments. Standard sound pressure levels were taken at an operator position of 1.5 m high and 1 m from source.

** Provided through Donaldson Torit fan program.

*** See system performance curves on page 12.

Addressing Safety Concepts

Donaldson Torit manufactures or partners with experts to provide solutions for critical processes where harmful particulate must be controlled.

- Explosion Relief Panels (with or without weather domes)
- Suppression Systems
- Reinforced Housing Construction



Downflo® Oval

Dimensions & Specifications

BASE MODULES 1-1, 2-2 & 3-3

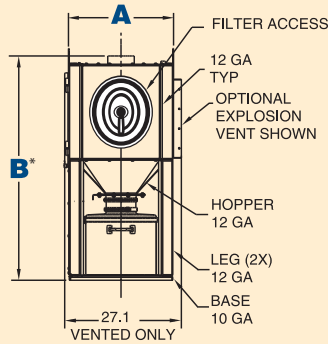

Front View
DFO 1-1

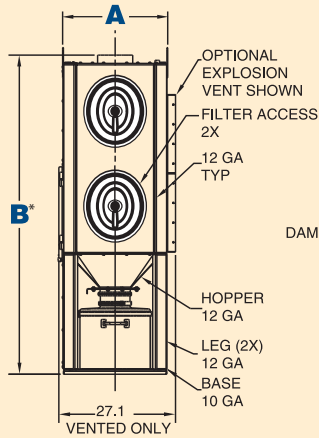

Front View
DFO 2-2

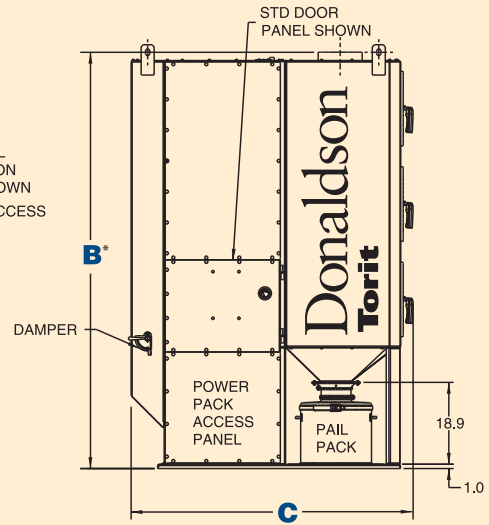

Left Side View
DFO 3-3

* Top of inlets.

BASE MODULES 2-4 THROUGH 4-128

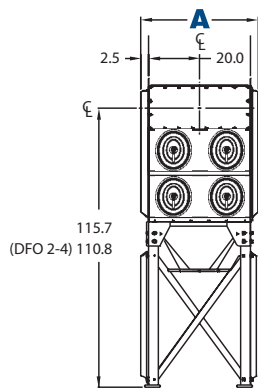

Front View
DFO 2-Models

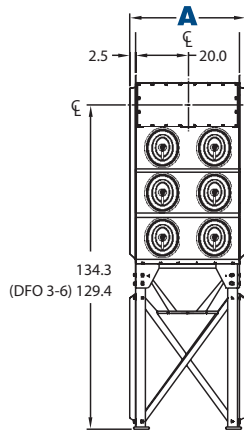

Front View
DFO 3-Models

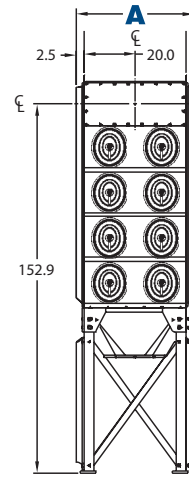

Front View
DFO 4-Models

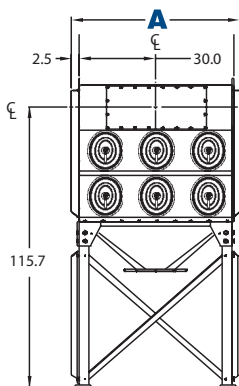

Front View
DFO 2-12
(3-Wide Models)

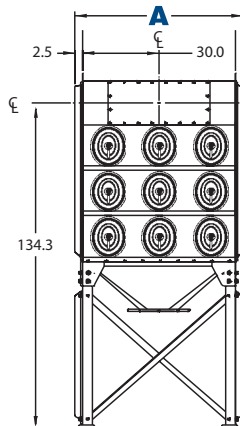

Front View
DFO 3-18
(3-Wide Models)

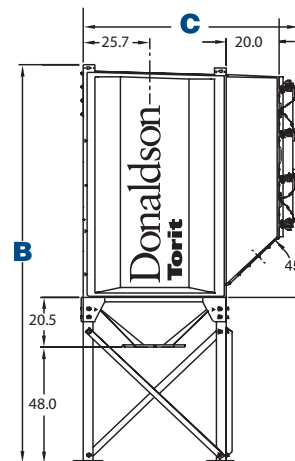

Right Side View
All Models

Dimensions & Specifications

Model*	Nominal Airflow Range** (cfm)	No. of Filters	Ultra-Web Filter Area (ft ²)	No. of Valves	Shipping Weight (lbs)	Dimensions (inches)		
						A	B	C
DFO 1 - 1	100-800	1	190	1	774	25.0	52.0	65.0
2 - 2	200-1,600	2	380	2	974	25.0	74.0	65.0
3 - 3	300-2,400	3	570	3	1,274	25.0	96.0	65.0
DFO 2 - 4	380-3,190	4	760	4	1,125	45.0	118.8	62.0
2 - 8	760-6,380	8	1,520	4	1,570	45.0	127.8	84.0
2 - 12	1,140-9,580	12	2,280	6	2,110	65.0	127.8	84.0
2 - 16	1,520-12,770	16	3,040	8	3,140	85.0	127.8	84.0
2 - 24	2,280-19,150	24	4,560	12	4,220	125.0	127.8	84.0
2 - 36	3,420-28,730	36	6,840	18	6,330	185.0	127.8	84.0
DFO 3 - 6	570-4,790	6	1,140	6	1,395	45.0	137.4	62.0
3 - 10	950-7,980	10	1,900	5	1,930	45.0	146.5	84.0
3 - 12	1,140-9,580	12	2,280	6	2,020	45.0	146.5	84.0
3 - 18	1,710-14,370	18	3,420	9	2,830	65.0	146.5	84.0
3 - 24	2,280-19,150	24	4,560	12	3,285	85.0	146.5	84.0
3 - 36	3,420-28,730	36	6,840	18	6,060	125.0	146.5	84.0
3 - 48	4,560-38,300	48	9,120	24	8,080	165.0	146.5	84.0
3 - 60	5,700-47,880	60	11,400	30	10,100	205.0	146.5	84.0
3 - 72	6,840-57,460	72	13,680	36	12,120	245.0	146.5	84.0
DFO 4 - 16	1,520-12,770	16	3,040	8	2,410	45.0	165.1	84.0
4 - 32	3,040-25,540	32	6,080	16	4,165	85.0	165.1	84.0
4 - 48	4,560-38,300	48	9,120	24	7,436	125.0	165.1	84.0
4 - 64	6,080-51,070	64	12,160	32	9,090	165.0	165.1	84.0
4 - 80	7,600-63,840	80	15,200	40	10,960	205.0	165.1	84.0
4 - 96	9,120-76,600	96	18,240	48	12,614	245.0	165.1	84.0
4 - 112	10,640-89,380	112	21,280	56	14,455	285.0	165.1	84.0
4 - 128	12,160-102,150	128	24,320	64	16,109	325.0	165.1	84.0

* The first number indicates number of filter rows, and the second number indicates number of cartridges.

** Based on clean filters.

Downflo[®] Oval

System Curves For DFO Models 1-1, 2-2 and 3-3

Powerful Performance Unlike other technologies that require upgrades for more demanding applications, each DFO 1-1, 2-2 and 3-3 footprint comes standard with a unique high performance power pack. The system performance graphs below show the fan performance with clean filters. The curve indicates available external static pressure to the unit.

DFO 1-1 1.5HP 60Hz with 6 in. inlet duct (clean filter)

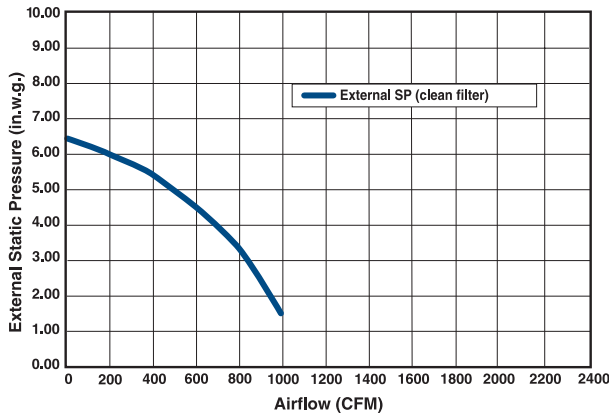

DFO 1-1 3HP 50Hz with 6 in. inlet duct (clean filter)

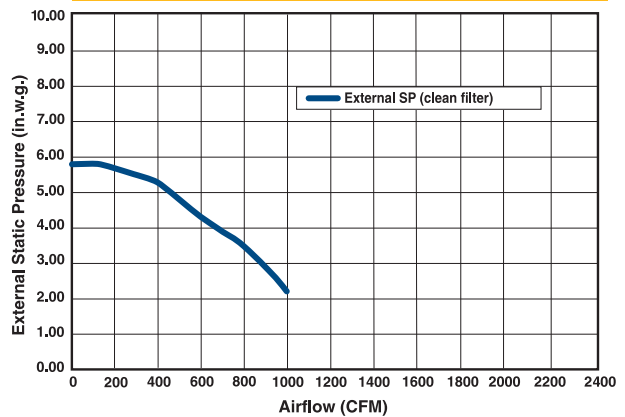

DFO 2-2 3HP 60Hz with 8 in. inlet duct (clean filters)

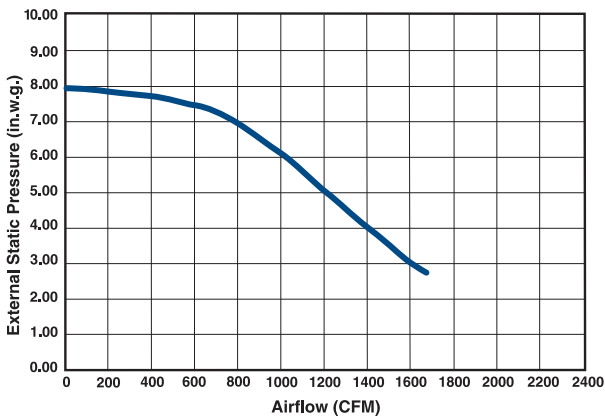

DFO 2-2 3HP 50Hz with 8 in. inlet duct (clean filters)

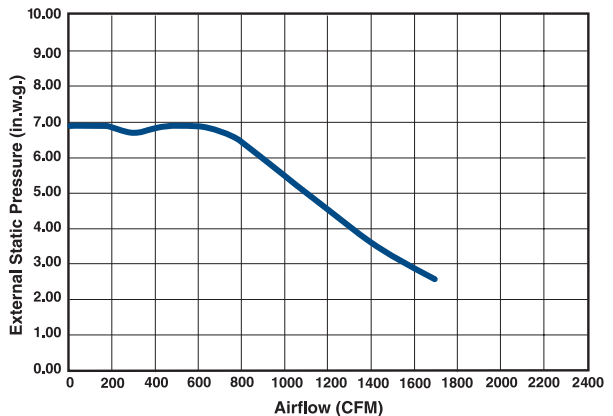

DFO 3-3 5HP 60Hz with 9 in. inlet duct (clean filters)

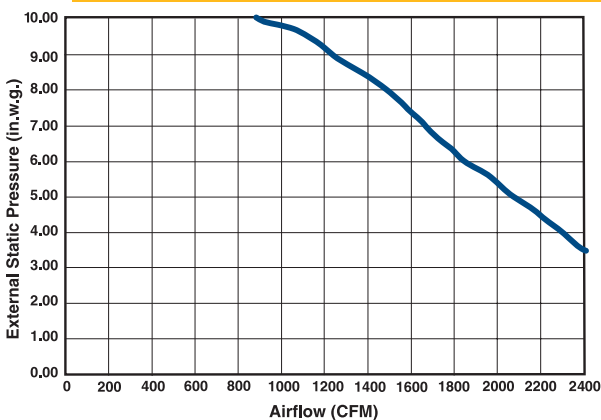

DFO 3-3 5HP 50Hz with 9 in. inlet duct (clean filters)

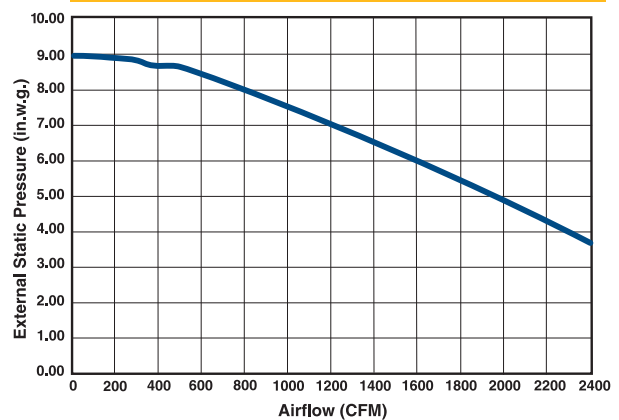

Downflo® Oval

Standard Features & Equipment Options

DFO 1-1, 2-2, 3-3

	Standard	Optional
Collector Design		
Mild Steel Construction	X	
Stainless Steel Construction		X
Explosion Protected Models		X
Integral High Performance Power Packs	X	
High Static Power Packs		X
ExtraLife™ Filter Cleaning System	X	
Quick-Removal Access Covers	X	
Integral Exhaust Silencer	X	
Airflow Damper	X	
Inlet Damper		X
Ledge-Free Hopper	X	
Inlet	X	
Abrasion Resistant (AR) Inlet		X
Sprinkler Taps	X	
Sprinkler Heads		X
Extraction Arms (7', 10', 14')		X
Caster Packs		X
Bag-Out Kit (Filter & Discharge)		X
Bag-In/Bag-Out Kit (Filter & Discharge)		X
Cartridge Filters		
Ultra-Web® Filters	X	
Variety of Cartridge Filters		X
HEPA Afterfilters		X
Paint System		
Electrostatically applied powder coat TGIC polyester texture finish (2-mil dry film thickness) inside and out. Paint system passed 350-hr. salt spray test.	X	
Custom Color		X
Hostile Environment Coating		X
Epoxy Coating		X
Hopper Discharge		
10-Gallon Pail Pack	X	
10-Gallon Pail Pack with Sealer Gear		X
25-Gallon Dust Container		X
Electrical Controls, Gauges, and Enclosures		
Minihelic® Gauge	X	
Manual or Automated Downtime Cleaning Controls	X	
Continuous On-Demand Torit® Delta P Control		X
Solenoid Enclosure in NEMA 12	X	
Solenoid Enclosure NEMA 9		X
Starter Controls		X
Warranty		
10-Year Warranty	X	

* Minihelic, Magnehelic and Photohelic are registered trademarks of Dwyer Instruments, Inc.

U.S. Patents 6,364,921; 6,488,746; 6,387,162; 6,368,388; 4,395,269; 5,562,746; 5,882,379

Information contained in this document is subject to change without notice.

DFO 2-4 Thru 4-128

	Standard	Optional
Collector Design		
Mild Steel Construction	X	
Stainless Steel Construction		X
High Temperature Construction		X
Explosion Protected Models		X
Direct Drive Fans		X
Chamber and Exhaust Silencers		X
ExtraLife™ Filter Cleaning System	X	
Quick-Removal Access Covers	X	
Inlets	X	
Abrasion Resistant (AR) Inlet		X
Air Management Modules		X
Extended Dirty Air Plenum		X
Ledge-Free Hopper	X	
Steep-Sided Hopper		X
2-Mod Hopper		X
Sprinkler Taps	X	
Sprinkler Heads		X
Service Platform (OSHA compliant)		X
Damper Pack		X
Drum Sentry™ Drum-Full Indicator		X
Lined Clean Air Plenum		X
Bag-Out Kit (Filter & Discharge)		X
Bag-In/Bag-Out Kit (Filter & Discharge)		X
Cartridge Filters		
Ultra-Web® Filters	X	
Variety of Cartridge Filters		X
HEPA Afterfilters		X
Paint System		
Prime Coated Interior	X	
Acrylic urethane finish over alkyd enamel primer. Paint system passes a 350-hr. salt spray test.	X	
Custom Color		X
Hostile Environment Coating		X
Epoxy Coating		X
Hopper Discharge		
Drum Cover and Hose		X
Slide Gates		X
Rotary Valves and Transitions		X
Screw Conveyors		X
Electrical Controls, Gauges, and Enclosures		
Control Box w/Timer in NEMA 4 Enclosure	X	
Delta P Control, Delta P Plus Control		X
Dustronix™ Control Assembly		X
Custom Panels		X
Magnehelic® Gauge	X	
Photohelic® Gauge Standard and Weatherproof		X
Basic Cold Climate Kit		X
Heavy-Duty Cold Climate Kit		X
Solenoid Enclosure (NEMA 7 & 9)		X
Warranty		
10-Year Warranty	X	

Donaldson® Torit® Look to Donaldson Torit for all of your air filtration needs. Although you may not always see our products, you can breathe easier knowing we're there.

Customer Support For nearly 90 years, Donaldson Torit has been the leading innovator of air filtration solutions that make manufacturing plants a cleaner environment for employees the world over. Driven by an unwavering commitment to customer support, Donaldson Torit is the name more manufacturers around the globe trust to deliver the most efficient and productive dust, mist and fume collectors and filter media.

Unparalleled Innovation Whether our customers need a single collector or a multi-faceted collection system, Donaldson Torit has the solution. The breadth of Donaldson Torit's innovative product line is unmatched, offering unparalleled filtration systems, ancillary parts and replacement filters. From central, source and ambient systems to baghouse, envelope and cartridge technologies, Donaldson Torit has the expertise to provide filtration solutions for virtually any application.

Global Reach Donaldson Torit manufactures and markets its filtration products throughout the world. As more manufacturers continue to expand and grow their operations globally, Donaldson Torit will be there to serve and support our customers' needs.

Built for Performance Genuine Donaldson Torit replacement filters and parts can significantly improve the performance of your collectors. With hundreds of varieties to choose from and all in-stock orders shipped within 48 hours, Donaldson Torit is your best, most reliable source for premium performance replacement parts. Visit us at www.donaldsondynamic.com.

Rely on the Industry Leader When it comes to air filtration, you need a partner you can trust. Rely on the world leader in air filtration—Donaldson Torit.



Donaldson®
Filtration Solutions

Donaldson Company, Inc.
Industrial Air Filtration
P.O. Box 1299
Minneapolis, MN
55440-1299 U.S.A.

Tel 800.365.1331 (USA)
Tel 800.343.3639 (within Mexico)
dustmktg@mail.donaldson.com
www.donaldsontorit.com



Printed in USA

© Donaldson Company, 2002 Downflo Oval 12-2004